

H-TYPE[®]

Precleaner with V- or VP-Tips

High Efficiency Tungsten-Carbide Precleaner

The Flexco H-Type[®] Precleaner with V- or Protected V-Tips is designed to be positioned on the head pulley and to remove the bulk of the carryback from the belt. Proven performance over 20 years as the most efficient precleaner in material handling applications such as coal, iron ore, bauxite and hard rock mining with vulcanized belts.

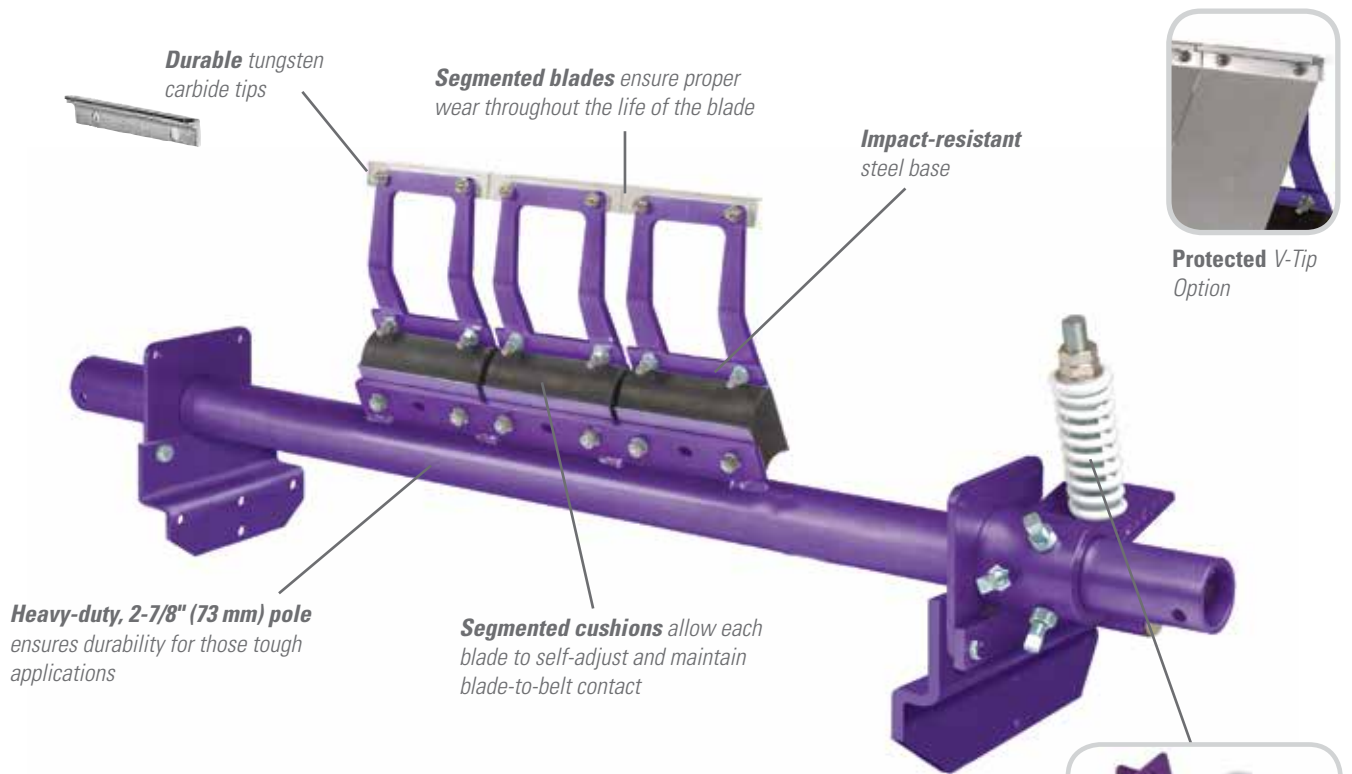

Protected V-Tip Option



Quick Mount Tensioner (QMT)
allows the blade tension to be visually inspected

Features and Benefits

- **Works with vulcanized belts.** The tungsten carbide tips allow for maximum cleaning efficiency and superior wear characteristics. Also available with protected tips for abrasive applications.
- **Complete cleaning system.** When teamed with a secondary cleaner, it makes up a system that delivers maximum cleaning power for the most abusive conveyor applications.
- **Made for mining conveyors.** Made from heavy-duty steel with corrosion-resistant powder coating, the H-Type is available in sizes for belt widths from 18" to 72" (450 to 1800mm). Additional sizes are available upon request.
- **Optimal positioning.** Blade contact on the pulley is 15° below the horizontal centerline. This keeps the blades out of the discharge path and protects them from rocks, large lumps and other debris.

H-TYPE® Precleaner with V- or VP-Tips

Specifications and Guidelines

Maximum Belt Speed

1000 FPM (5 M/sec)

Temperature Rating

-30° F to 180° F (-35° C to 82° C)

Minimum Pulley Diameter

10" (250mm)

CEMA Cleaner Rating

Class 4

Usable Blade Wear Length

3/8" (9mm)

Blade Material

Tungsten carbide (for vulcanized belts only)

Available for Belt Widths

18" to 72" (450 to 1800mm)

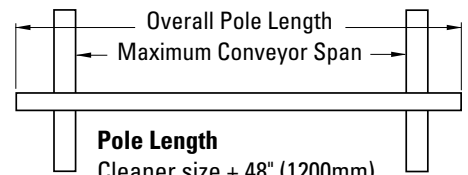

Pole Length

Cleaner size + 48" (1200mm)

Maximum Conveyor Span

Cleaner size + 38" (950mm)

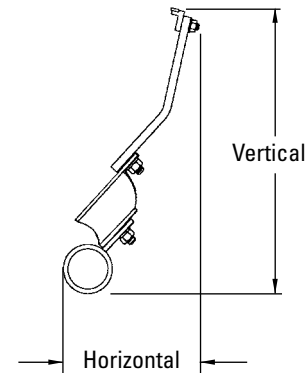

Horizontal Clearance Required
7" (175mm)

Vertical Clearance Required

SS: 13" (325mm)

S: 15" (375mm)

M: 16-1/2" (413mm)

L: 18-1/2" (463mm)

LL: 22" (550mm)

Ordering Information

H-Type® with V-Tips*

Belt Width	Suspension	Ordering	Item	
in.	mm	Arm Size	Number	Code
18	450	SS	HV-18SS	76101
18	450	S	HV-18S	76190
18	450	M	HV-18M	76191
24	600	SS	HV-24SS	76102
24	600	S	HV-24S	76192
24	600	M	HV-24M	76193
30	750	SS	HV-30SS	76103
30	750	S	HV-30S	76194
30	750	M	HV-30M	76195
36	900	SS	HV-36SS	76104
36	900	S	HV-36S	76196
36	900	M	HV-36M	76197
36	900	L	HV-36L	76198
42	1050	SS	HV-42SS	76105
42	1050	S	HV-42S	76199
42	1050	M	HV-42M	76251
42	1050	L	HV-42L	76252
42	1050	LL	HV-42LL	76253
48	1200	SS	HV-48SS	76106
48	1200	S	HV-48S	76254
48	1200	M	HV-48M	76255
48	1200	L	HV-48L	76256
48	1200	LL	HV-48LL	76257
54	1350	S	HV-54S	76107
54	1350	M	HV-54M	76258
54	1350	L	HV-54L	76259
54	1350	LL	HV-54LL	76260
60	1500	S	HV-60S	76108
60	1500	M	HV-60M	76261
60	1500	L	HV-60L	76262
60	1500	LL	HV-60LL	76263
72	1800	S	HV-72S	76109
72	1800	M	HV-72M	76264
72	1800	L	HV-72L	76265
72	1800	LL	HV-72LL	76266

*NOTE: V-Tips can be used ONLY on vulcanized belts. Suspension arm size is determined by head pulley diameter - see chart. Additional sizes available upon request. Lead time: 1 working day

H-Type with Protected V-Tips*

For abusive applications where materials being cleaned off the belt wear the back sides of the cleaner's V-Tips.

Belt Width	Suspension	Ordering	Item	
in.	mm	Arm Size	Number	Code
18	450	S	HVP-18S	76124
18	450	M	HVP-18M	76267
18	450	L	HVP-18L	76268
24	600	S	HVP-24S	76125
24	600	M	HVP-24M	76269
24	600	L	HVP-24L	76270
30	750	S	HVP-30S	76126
30	750	M	HVP-30M	76271
30	750	L	HVP-30L	76272
36	900	S	HVP-36S	76127
36	900	M	HVP-36M	76273
36	900	L	HVP-36L	76274
42	1050	S	HVP-42S	76128
42	1050	M	HVP-42M	76275
42	1050	L	HVP-42L	76276
48	1200	S	HVP-48S	76129
48	1200	M	HVP-48M	76277
48	1200	L	HVP-48L	76278
48	1200	LL	HVP-48LL	76279
54	1350	S	HVP-54S	76130
54	1350	M	HVP-54M	76280
54	1350	L	HVP-54L	76281
54	1350	LL	HVP-54LL	76282
60	1500	S	HVP-60S	76131
60	1500	M	HVP-60M	76283
60	1500	L	HVP-60L	76284
60	1500	LL	HVP-60LL	76285
72	1800	S	HVP-72S	76132
72	1800	M	HVP-72M	76286
72	1800	L	HVP-72L	76287
72	1800	LL	HVP-72LL	76288

*NOTE: Protected V-Tips can be used ONLY on vulcanized belts. Suspension arm size is determined by head pulley diameter - see chart. Cleaners come standard with Stainless Steel Tip Shields. Additional sizes available upon request. Lead time: 1 working day

Suspension Arm Size		
Head Pulley Diameter + Belt & Lagging		Suspension Arm Size
in.	mm	
10 - 19	250-475	SS
20 - 31	500-775	S
32 - 39	800-975	M
40 - 47	1000-1175	L
48 - 67	1200-1675	LL

Replacement V-Tips

Ordering Number	Item Code
HVT8	73042

Lead time: 1 working day

Replacement Protected V-Tips

Ordering Number	Item Code
HVPT	73631

Lead time: 1 working day

Authorized Distributor:

Distribution in Europe by:

Flexco Europe GmbH • Leidringer Strasse 40-42 • D-72348 Rosenfeld • Germany

Phone: +49-7428-9406-0 • Fax: +49-7428-9406-260 • E-mail: europe@flexco.com • Web: www.flexco.com

